

Nastavovanie dosák a prúťov

- 1) Rozširovacie väzby
- 2) Zvlaky a okrajnice
- 3) Nastavovanie na dĺžku

1) Rozširovacie väzby

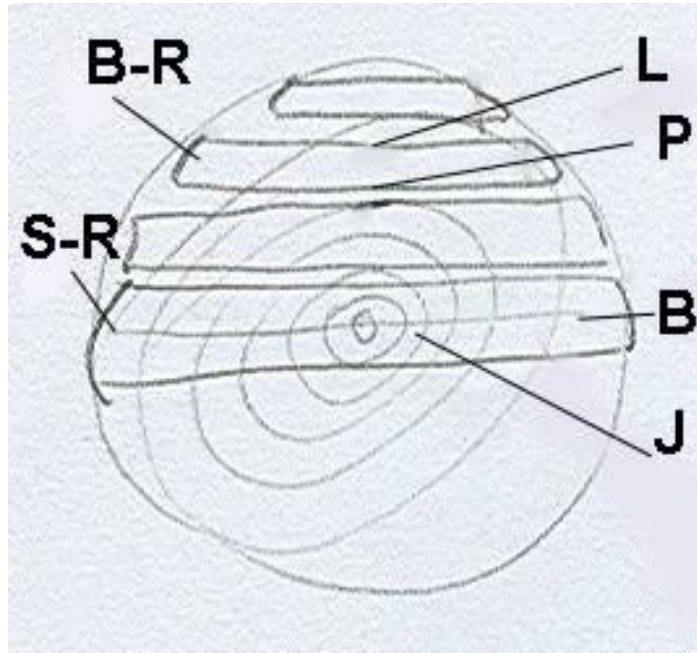

L = ľavá strana (bližšie k okraju), „viac“ tangenciálna

P = pravá strana (bližšie k stredu), „menej“ tangenciálna

B = beľová časť

J = jadrová časť

B-R = bočné (tangenciálne) rezivo

S-R = stredové (radiálne) rezivo

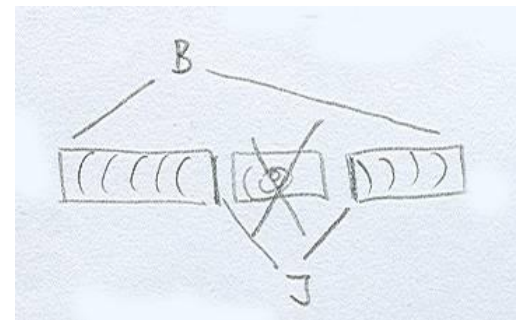

Šúverenie

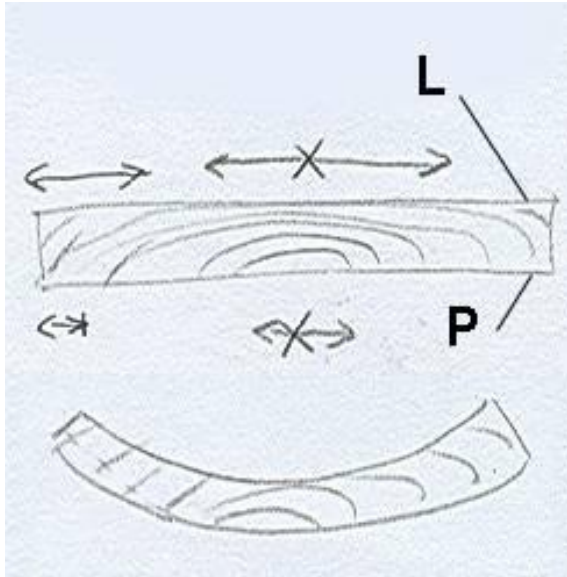

bočné rezivo

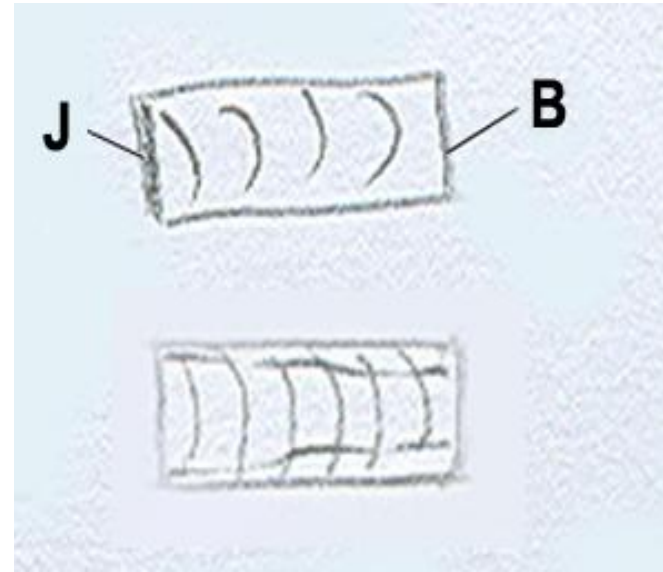

stredové rezivo

Skladba

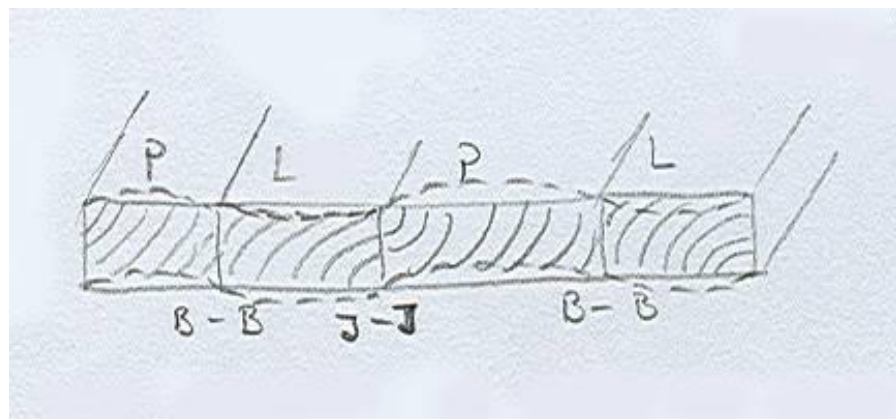

bočné rezivo

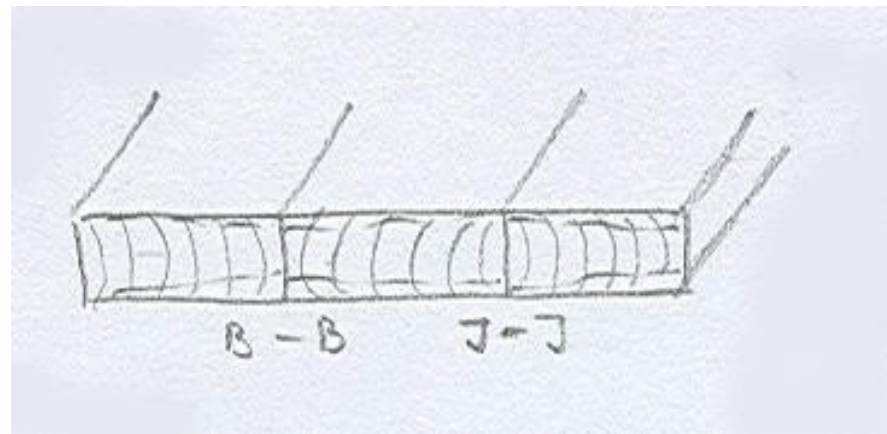

stredové rezivo

Šúverenie



Menšia rovinnosť,
väčšia hrúbka

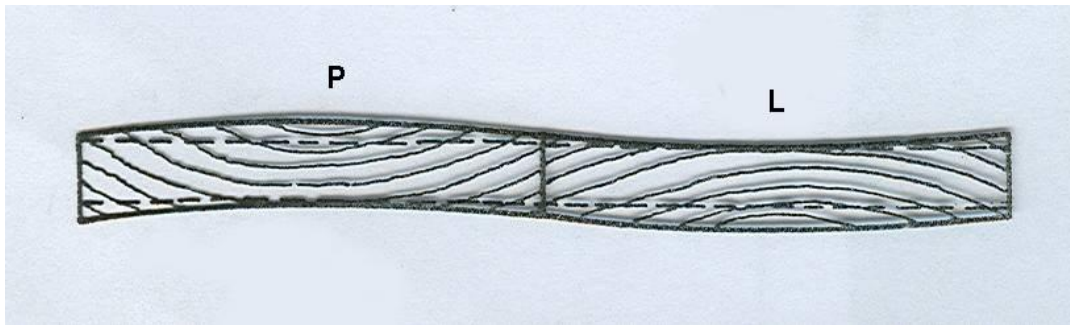

Väčšia rovinnosť,
menšia hrúbka

Bočné rezivo

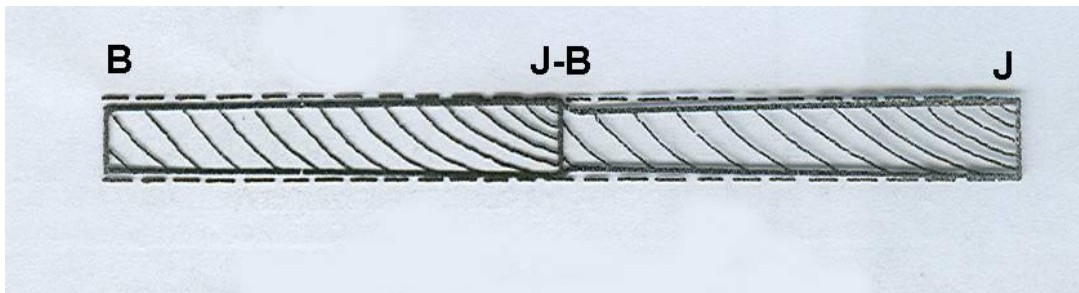

Nerovný povrch

Stredové rezivo

Lepenie a šúverenie širokých dosák na hrúbku

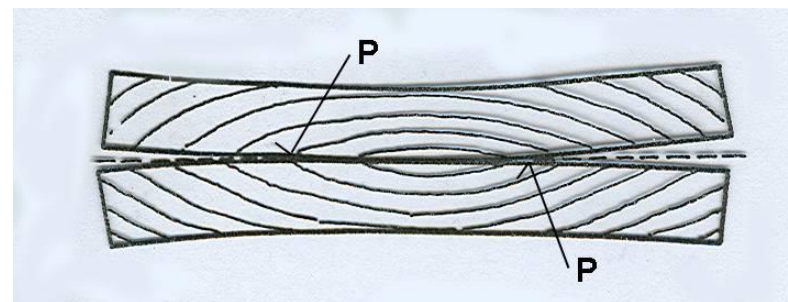
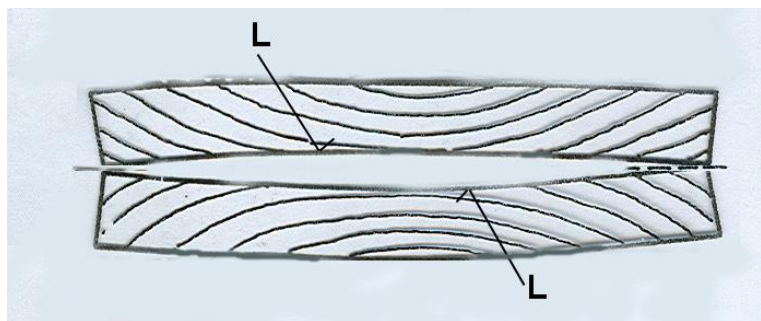
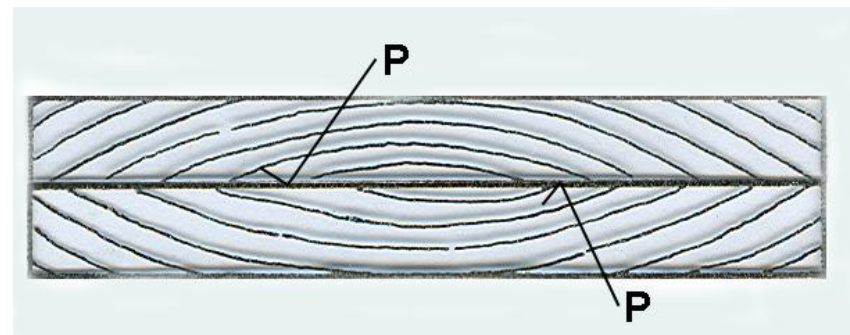
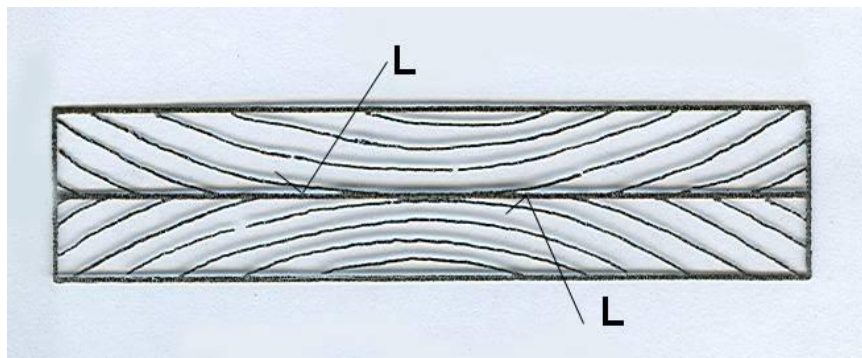

Ľavými stranami –
vhodné (rozlepenie od
stredu)

Pravými stranami –
nevhodné (rozlepenie od
okrajov)

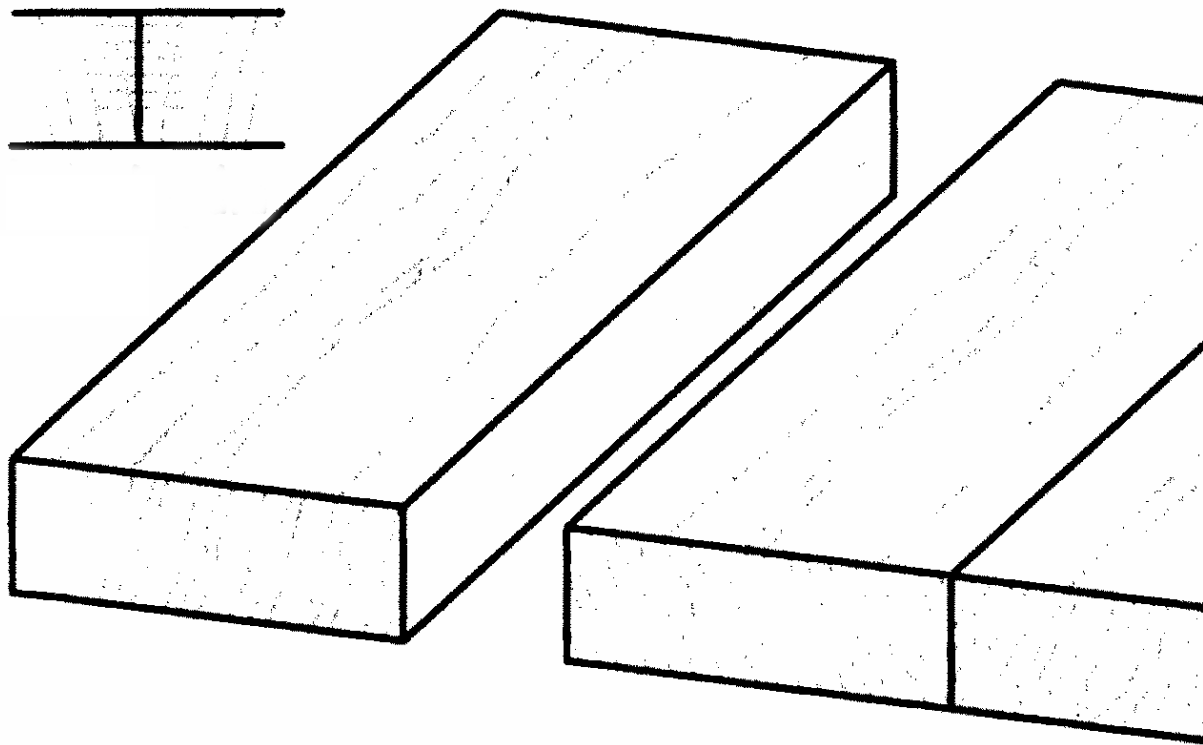

Na tupo - lepená škára

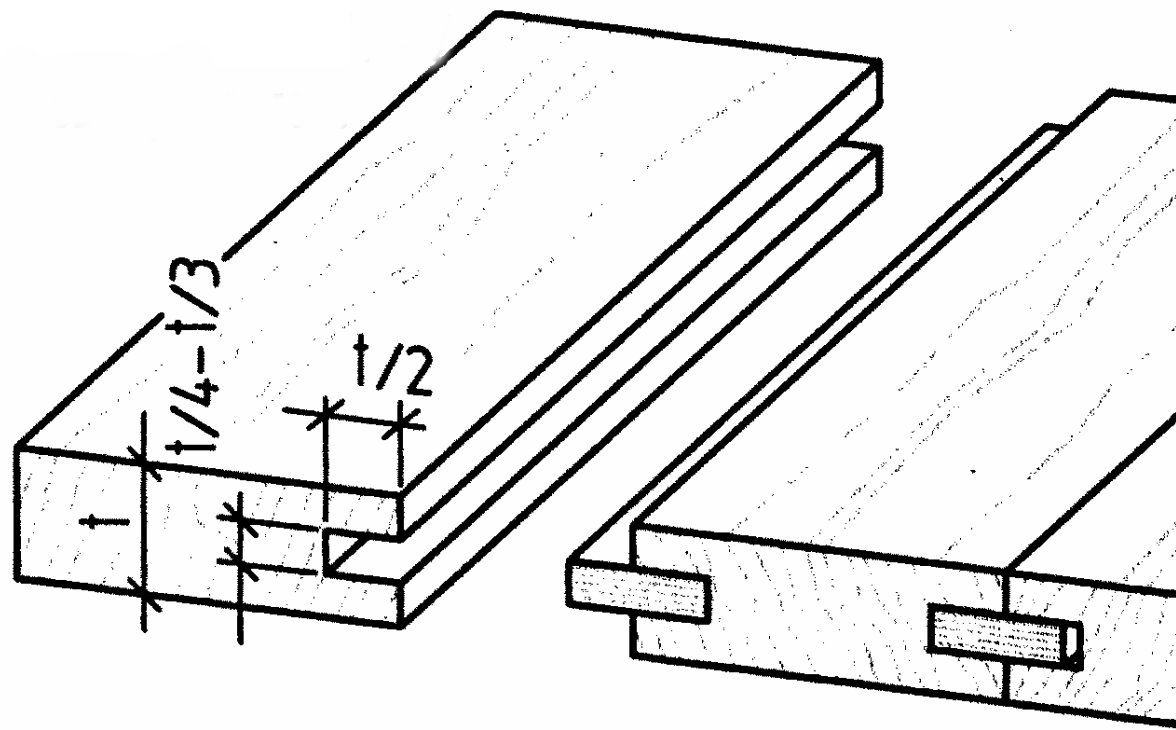

Vložené pero – zväčšenie lepenej škáry

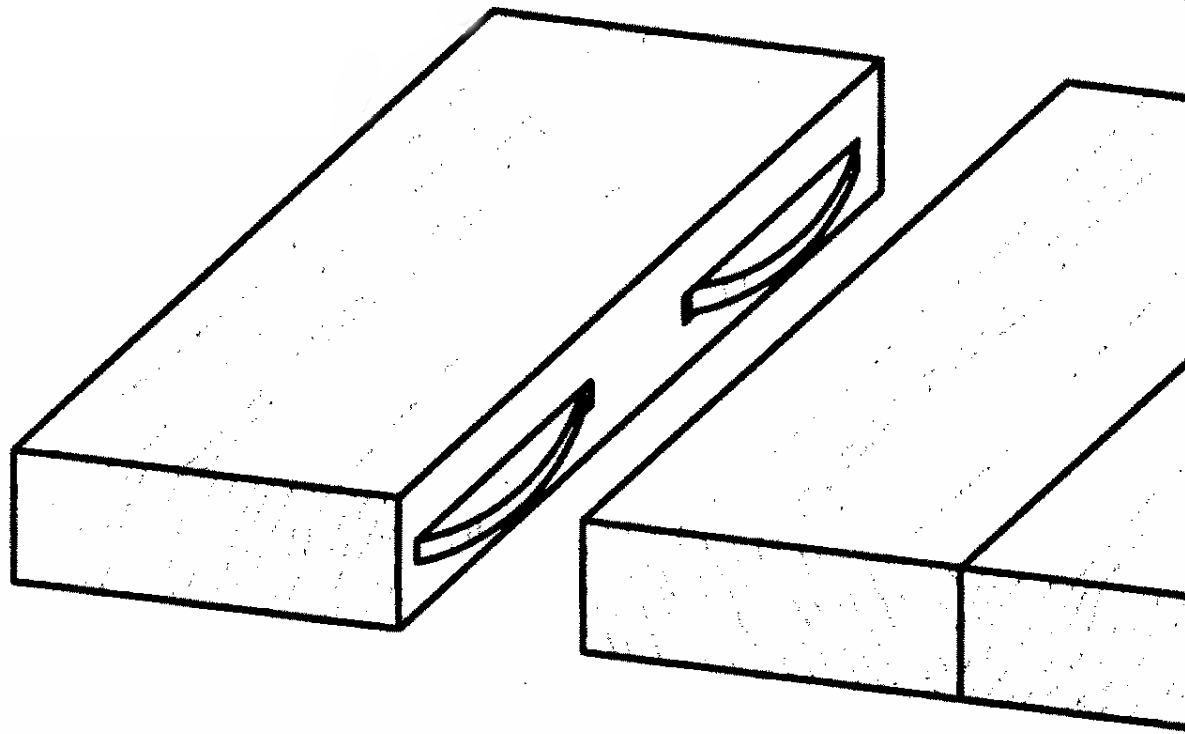

Spoj s lamellom - tvarované pero

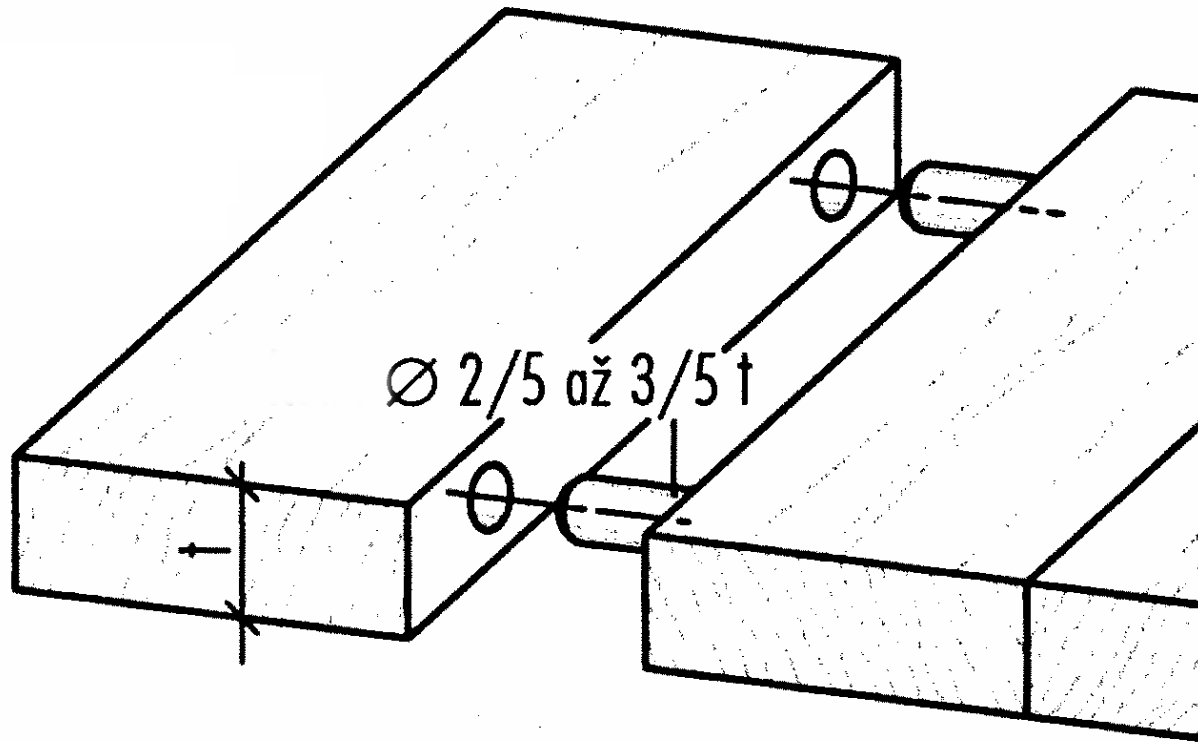

Na tupo – škára zaistená kolíkmi

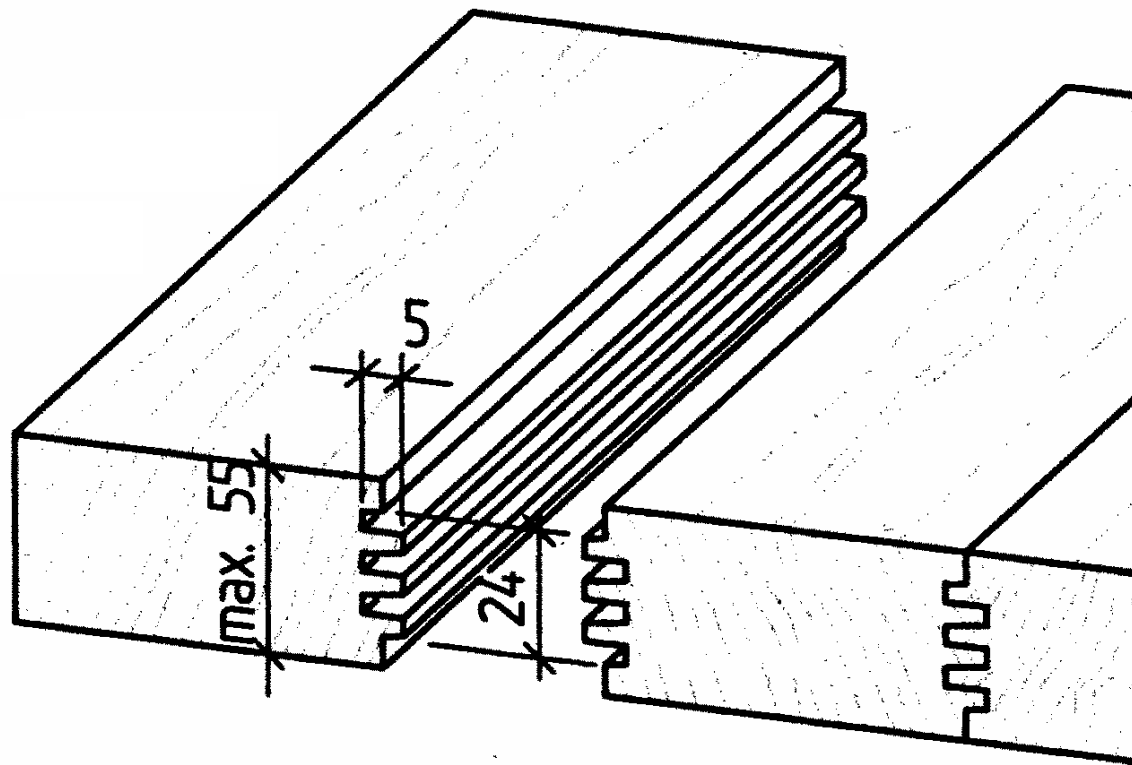

Zubovitá tupá škára

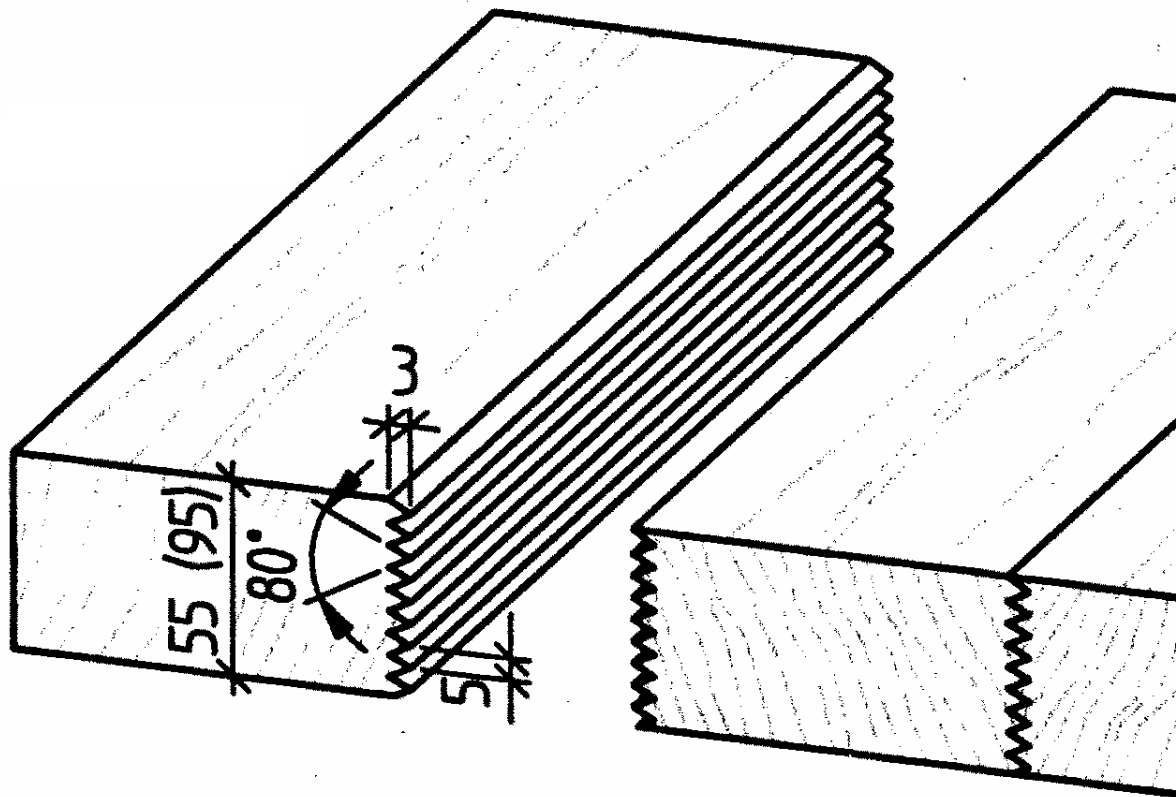

Klinové ozuby

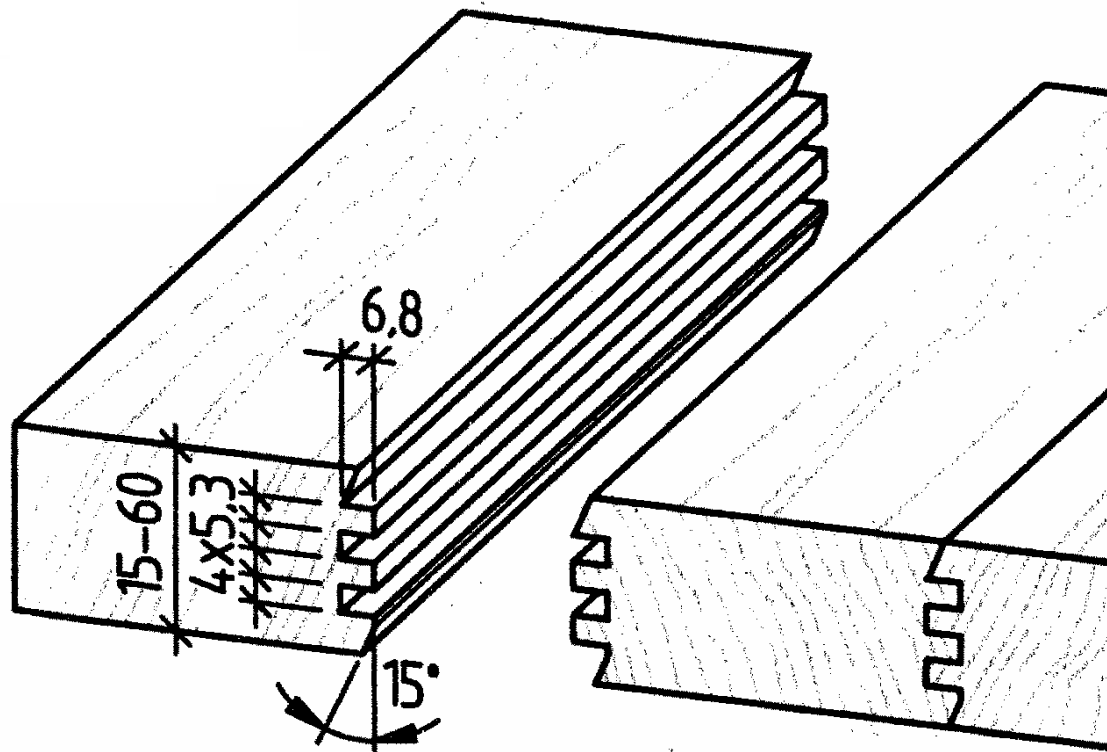

Viacnásobné pero a drážka

2) Zvlaky a okrajnice

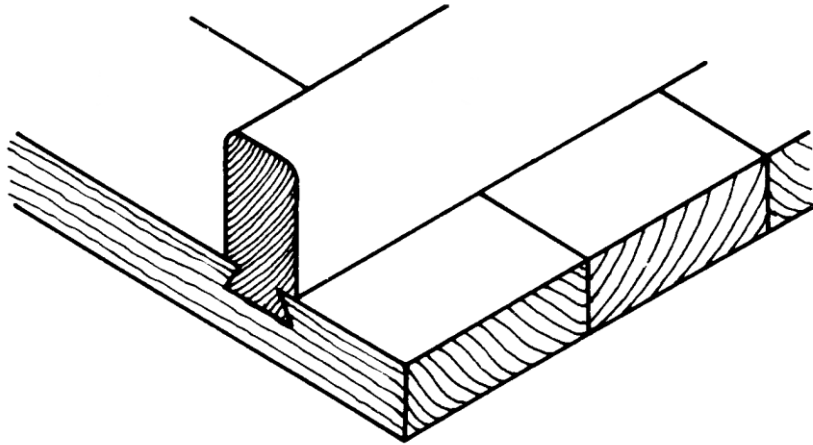

Zvlak

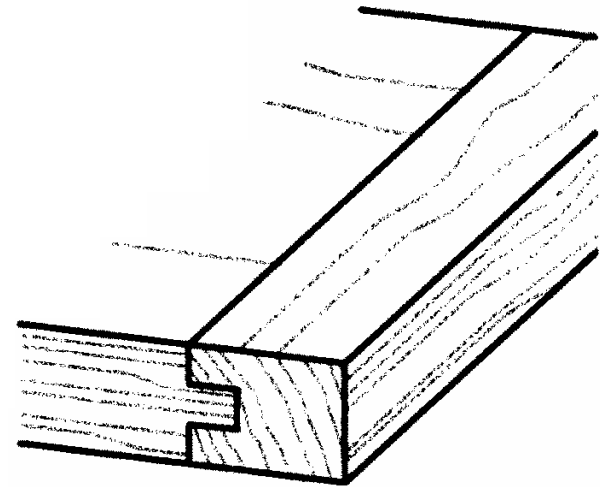

Okrajnica (privlačka)

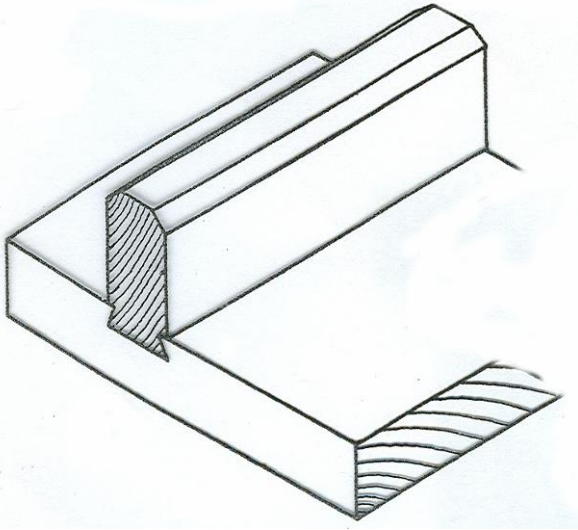

Zvlak vysoký

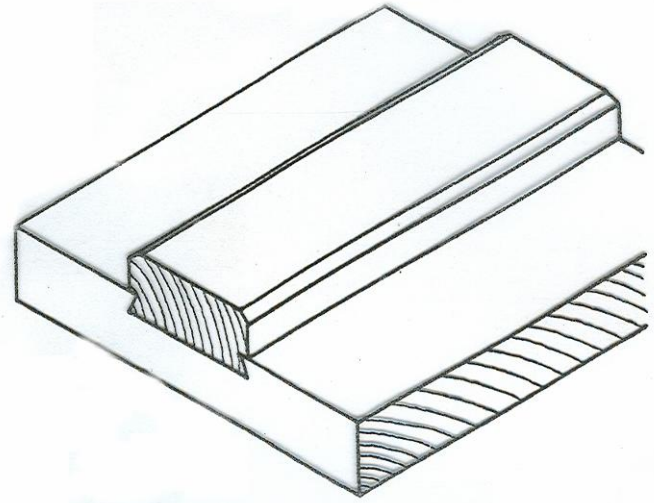

Zvlak nízky

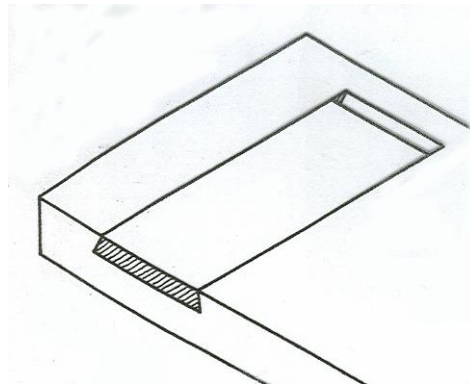

Zvlak zapustený

Zvlak – geometrické parametre

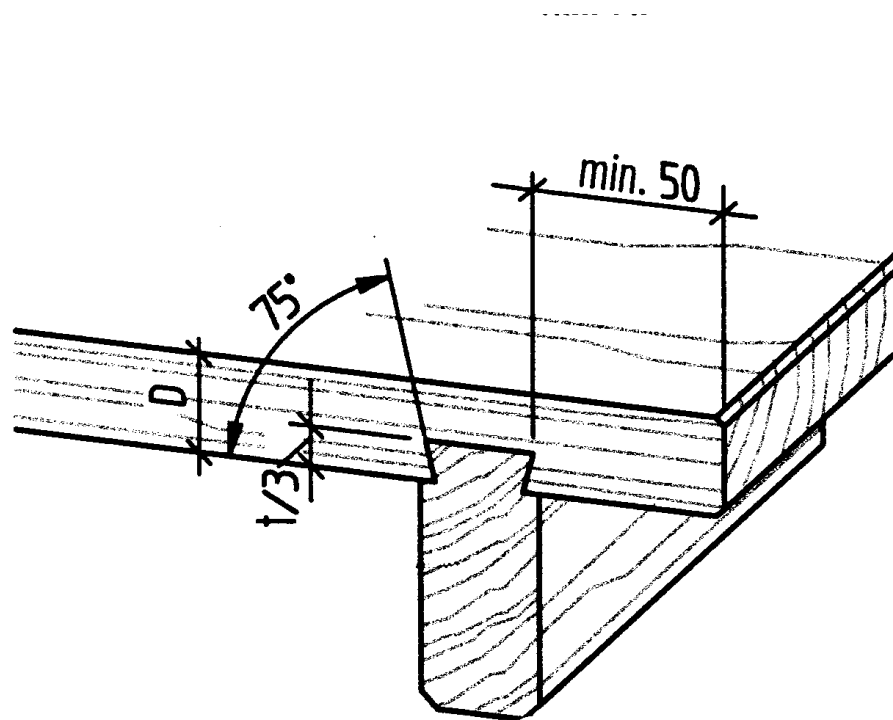

Zvlak – geometrické parametre

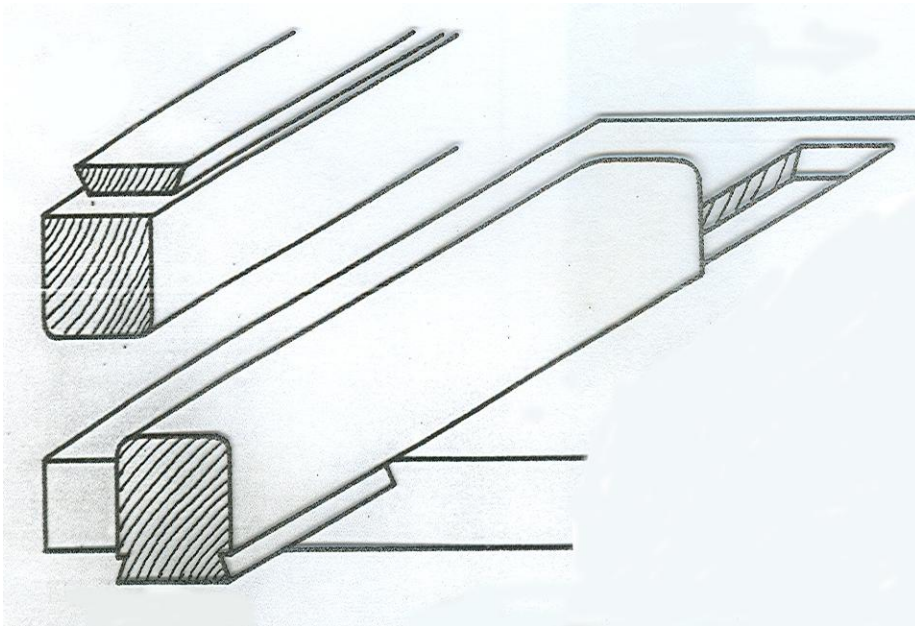

Zvlak – nepriebežná
zvlaková lišta

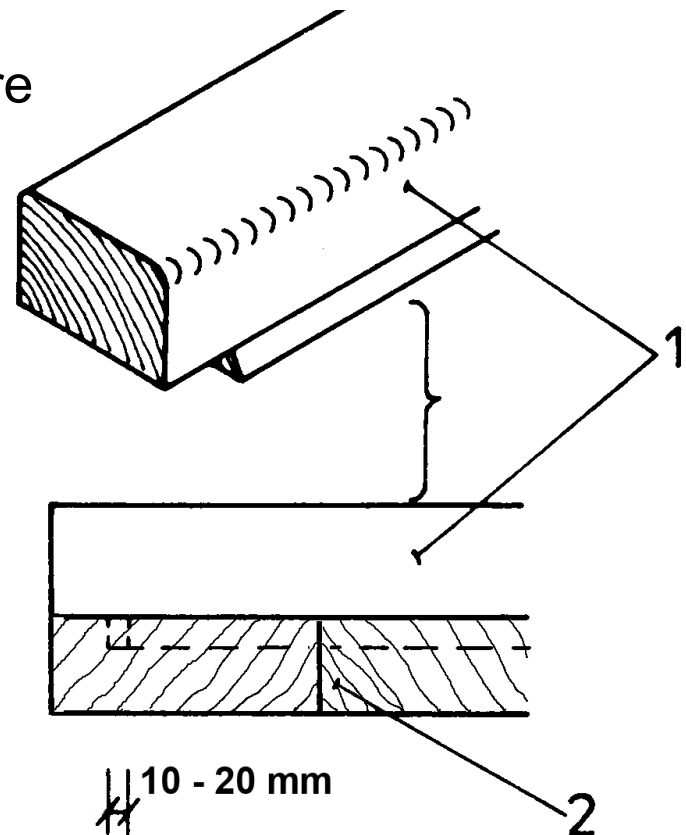

Zvlak – drážka musí byť 10-
20 mm dlhšia ako zvlakové
pero; 1 – zvlaková lišta,
2 - škárovka

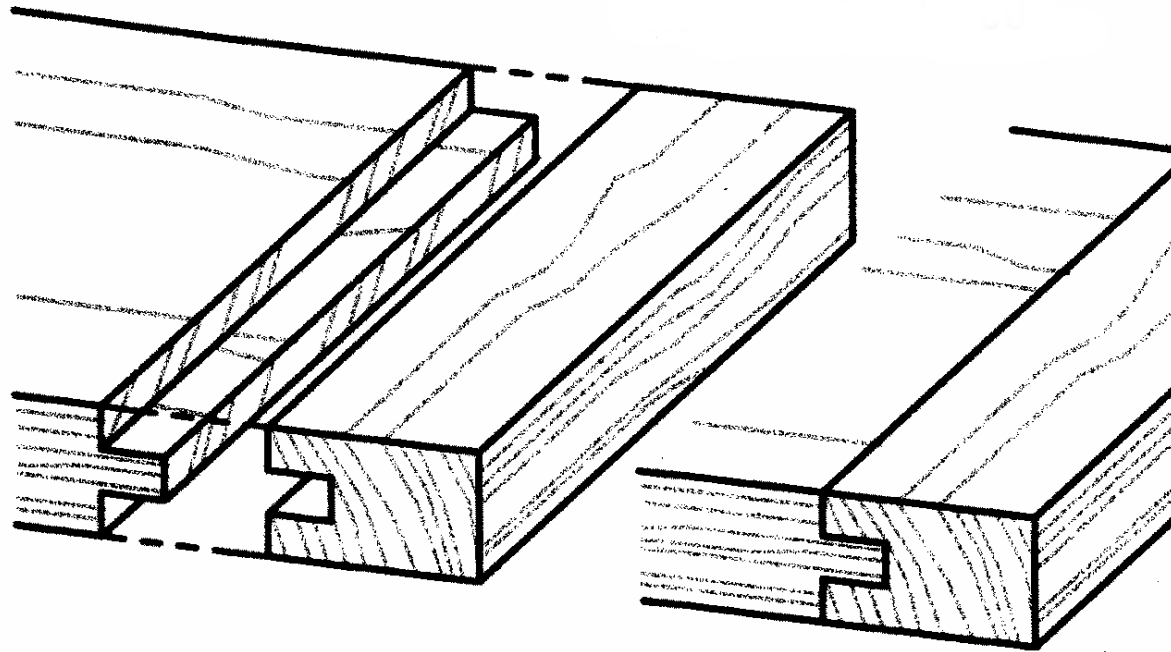

Okrajnica s drážkou

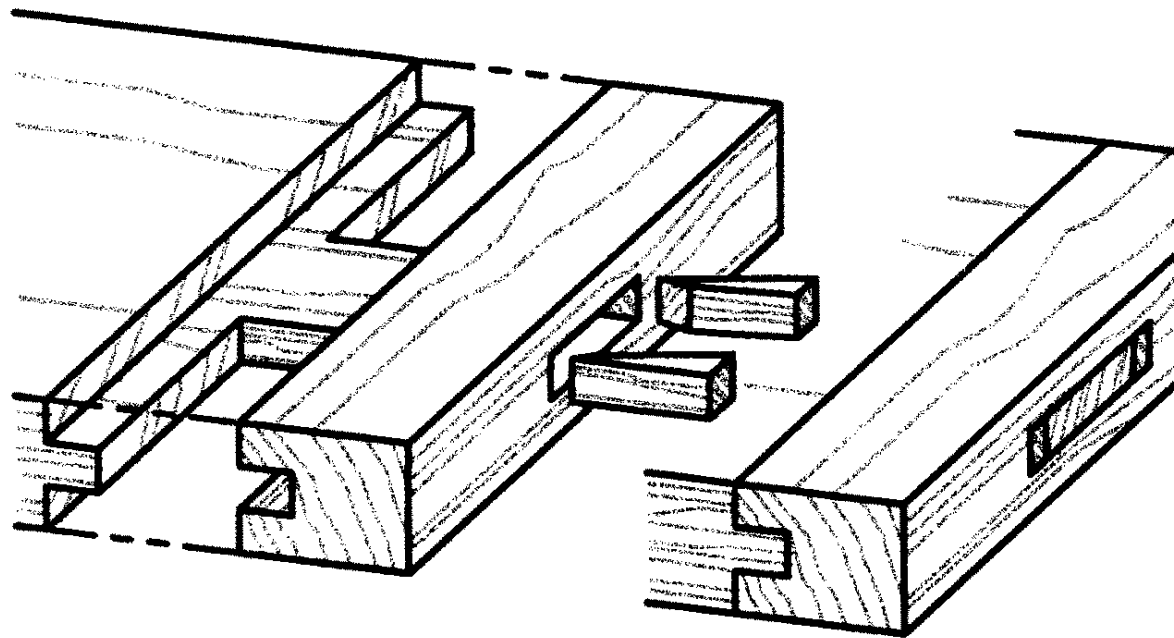

Okrajnica s drážkou a s čapom - zaklinovaná

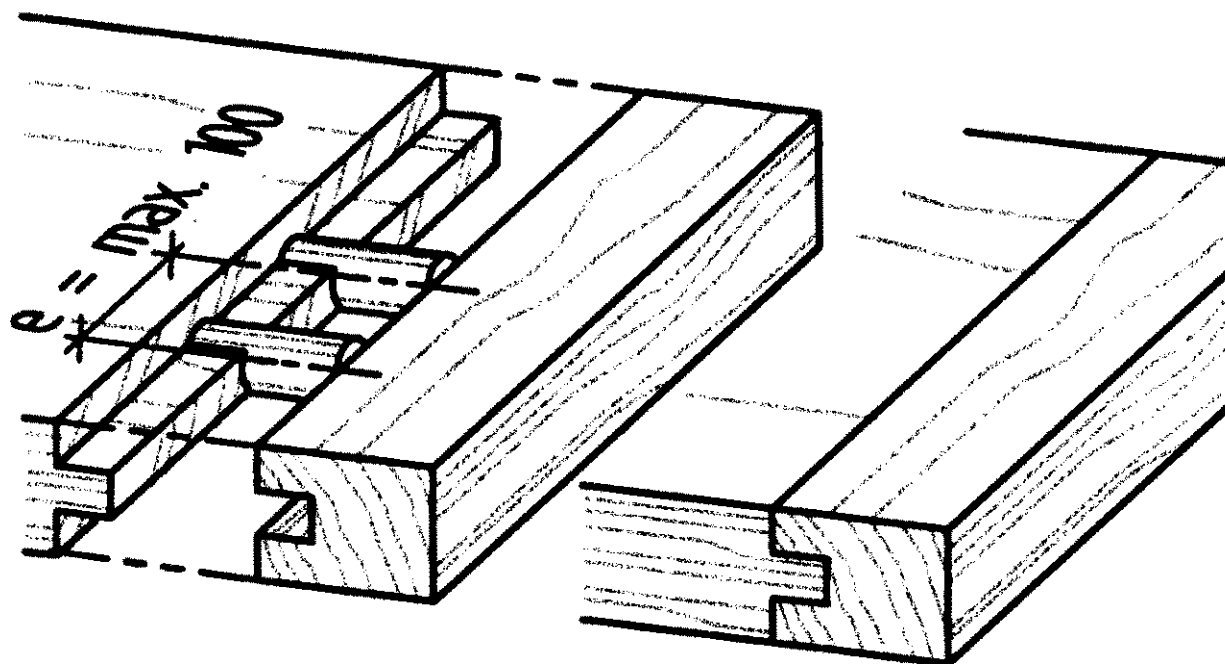

Okrajnica s drážkou a s kolíčky

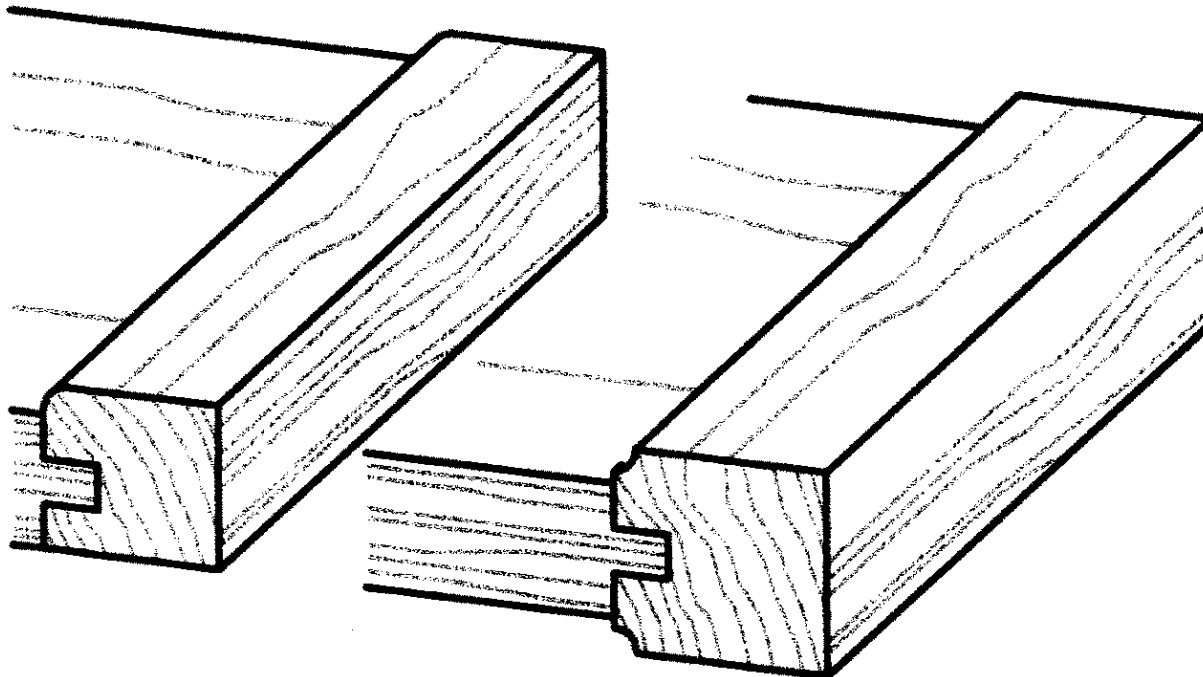

Okrajnica s drážkou - hrubá

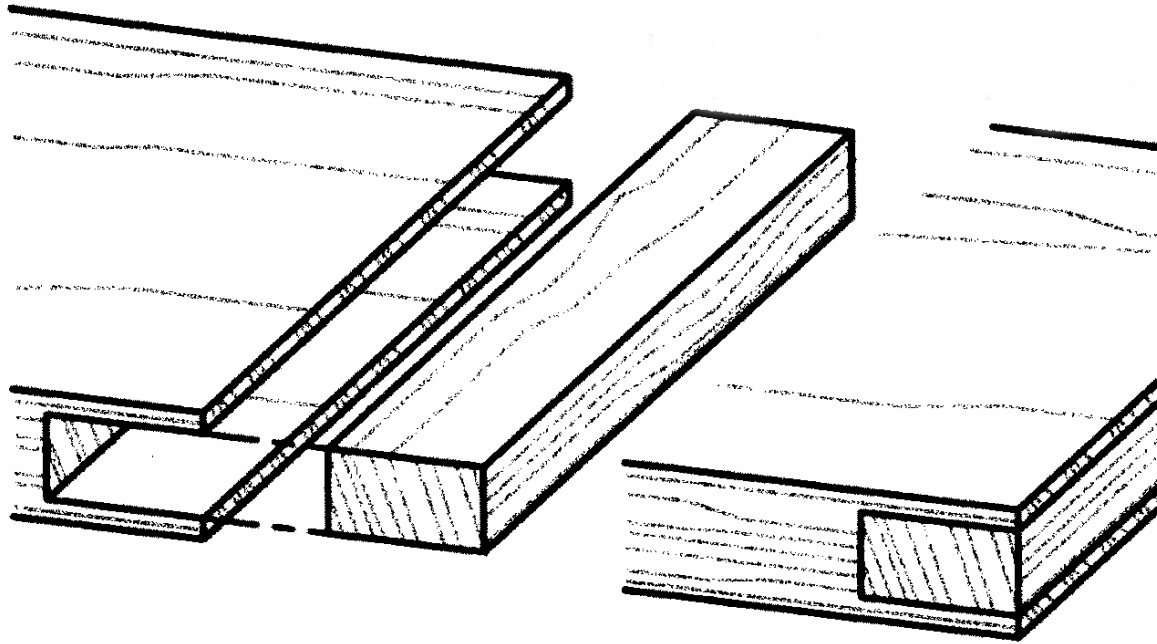

Okrajnica obdĺžniková - vlepená (náglejok)

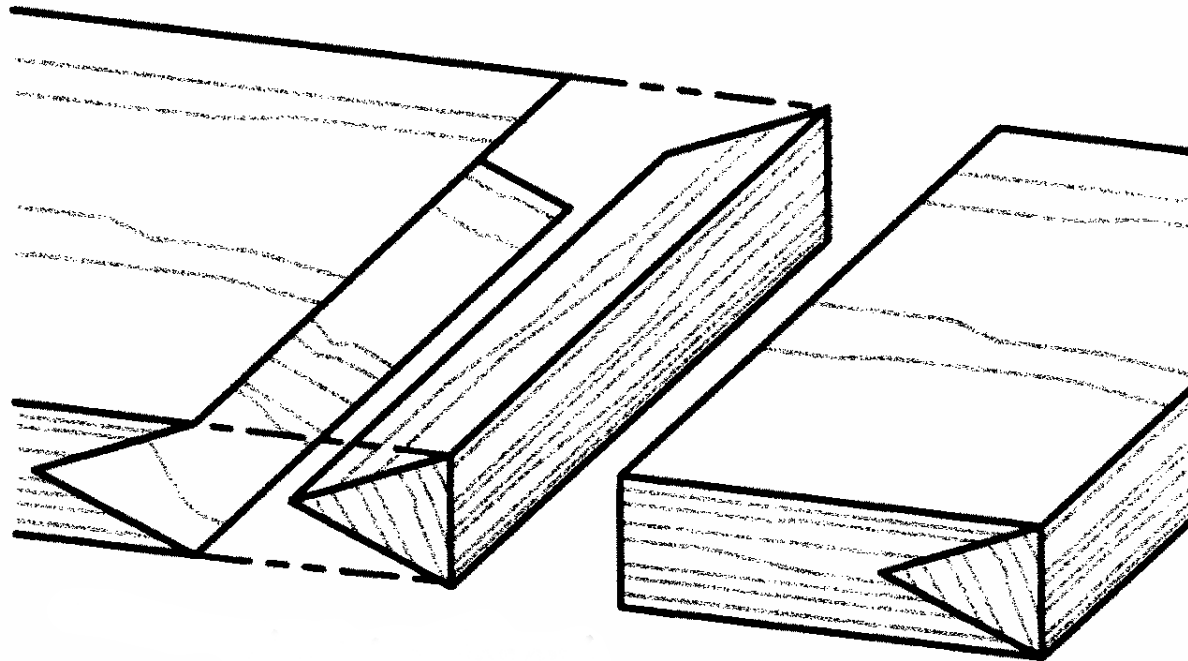

Okrajnica klinová - vlepená (náglejok)

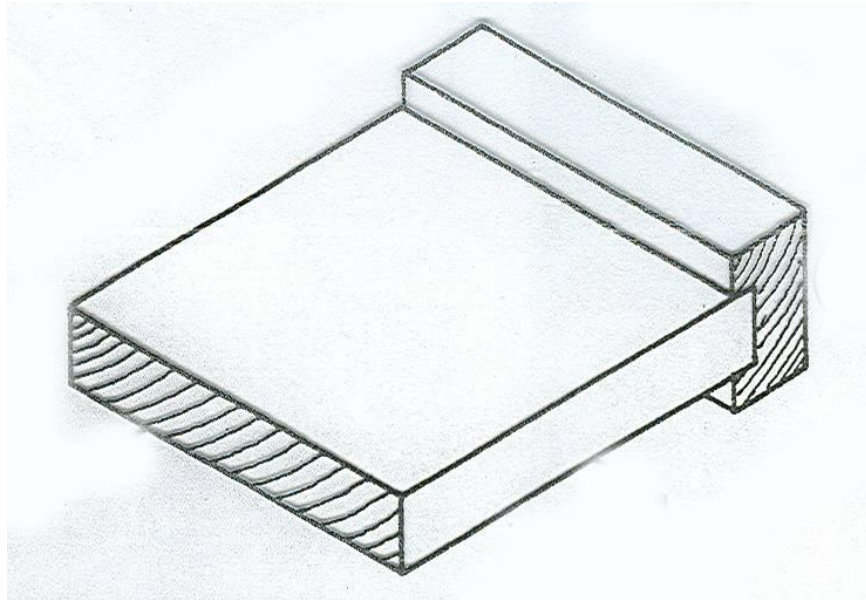

Okrajnica so zapustením na celú hrúbku, hrubá

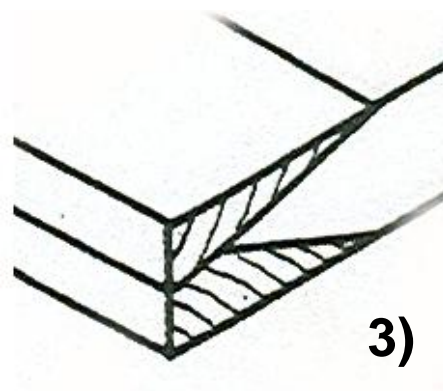
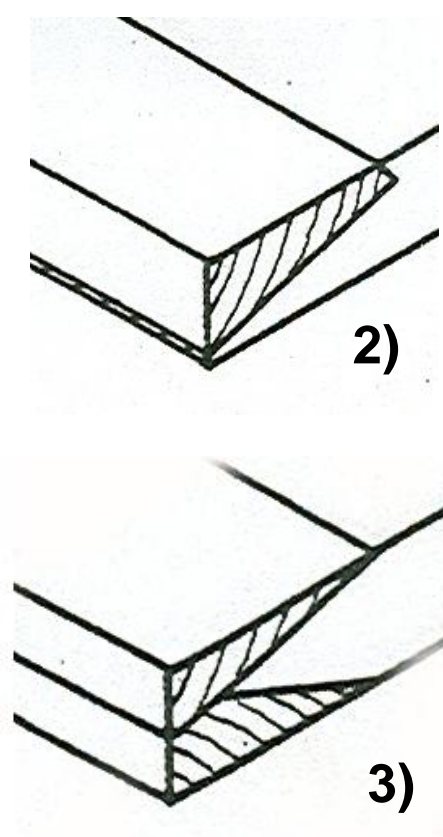
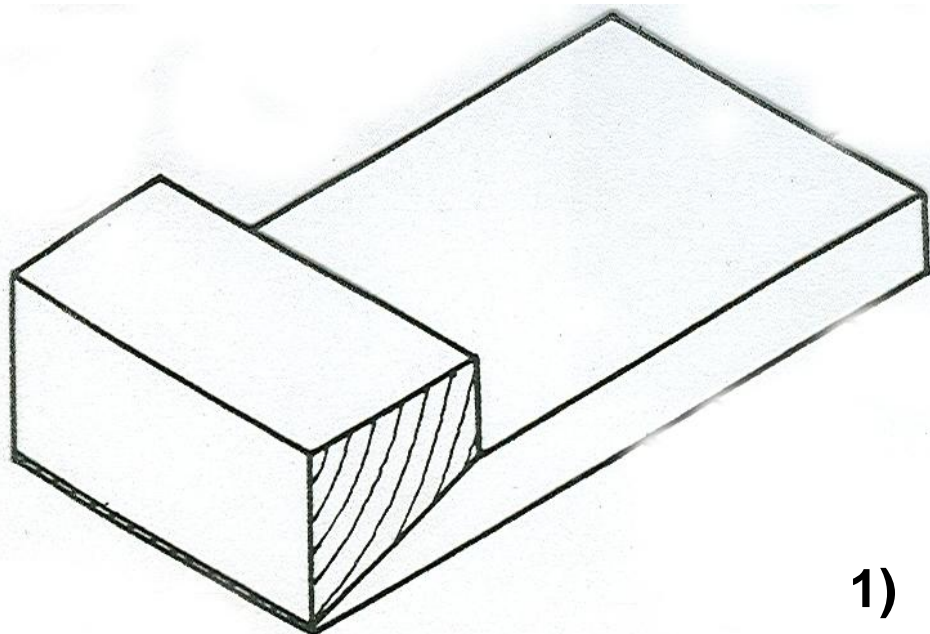

Okrajnica so zošikmením

1- hrubá

2 – zarovnaná v rovine dosky

3- dve časti, zarovnané v rovine dosky

3) Nastavovanie na dĺžku

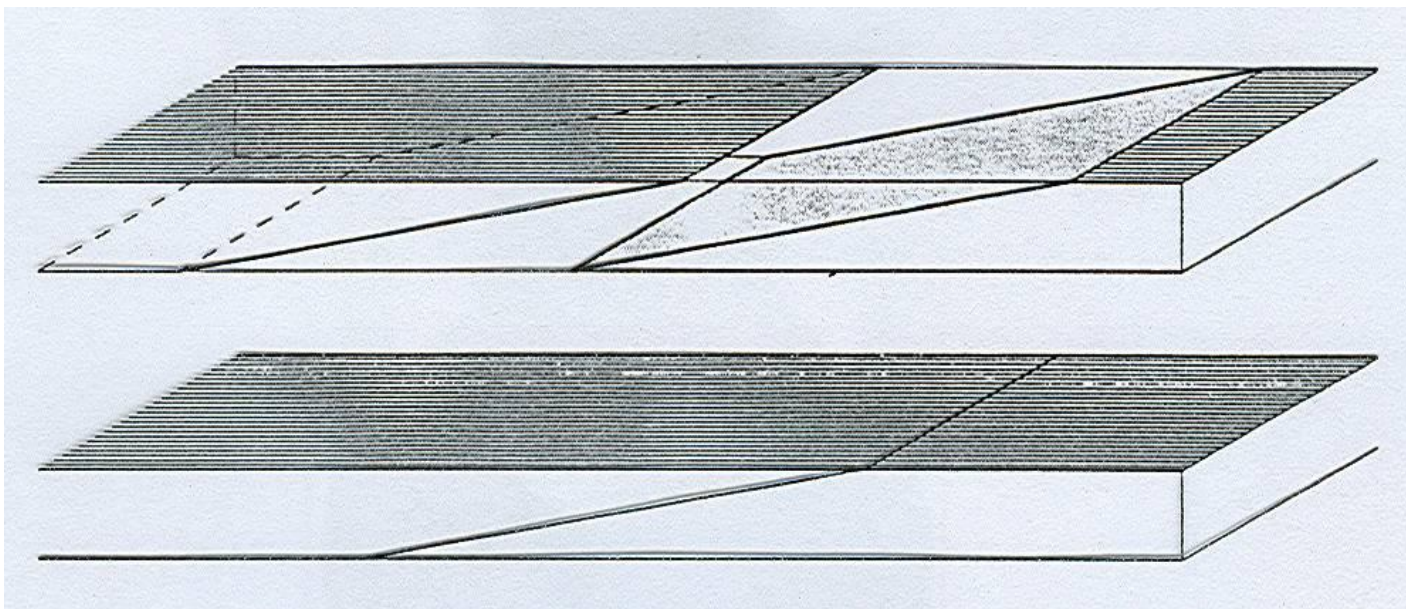

Zošikmenie (na úkos)

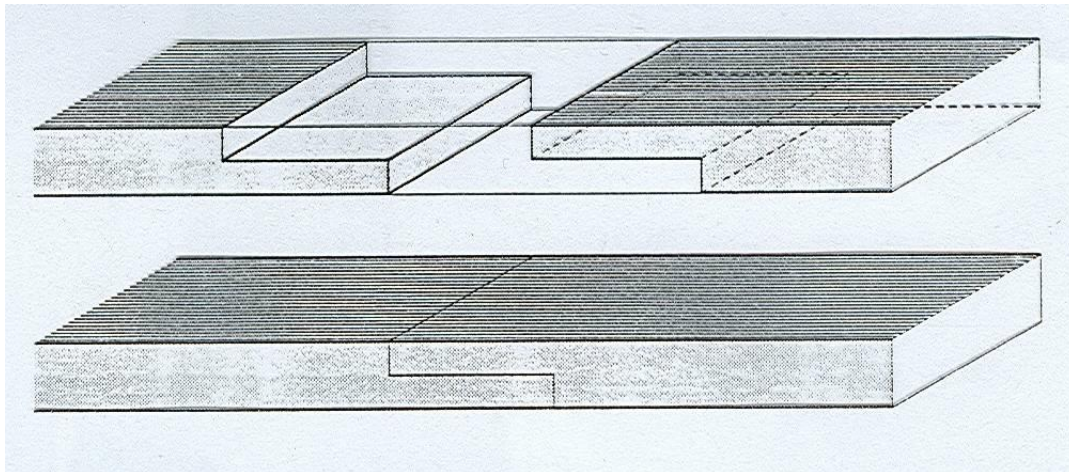
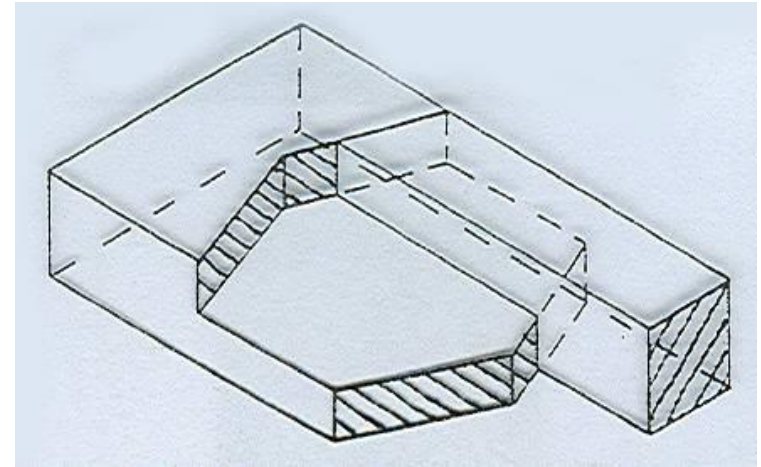
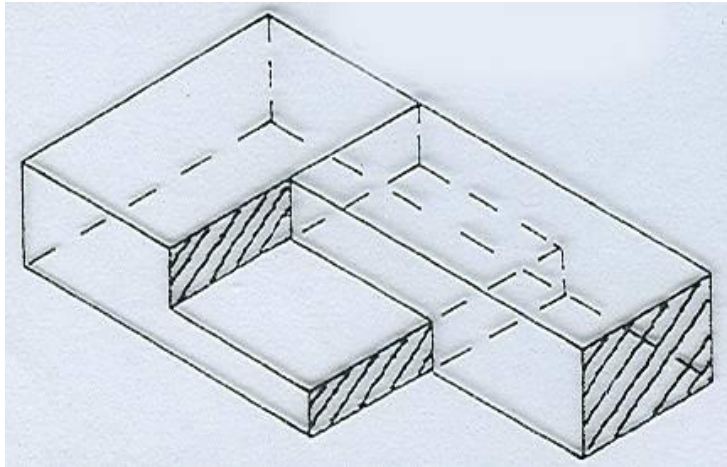

**Preplatovanie – so šikmou
prednou hranou**

Preplatovanie - jednoduché

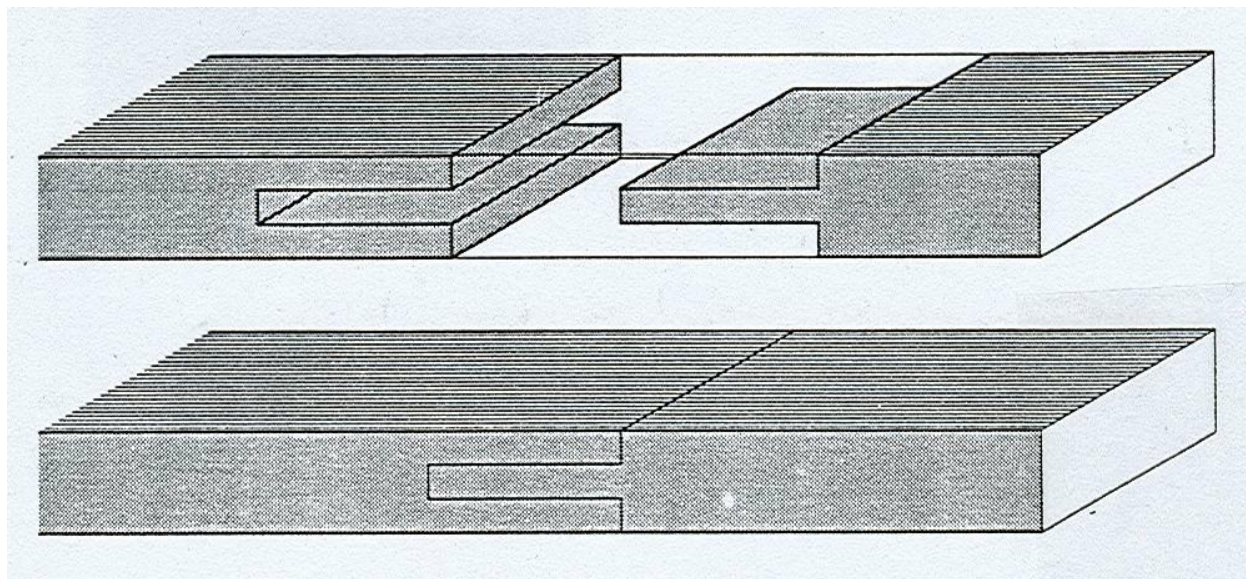

Jednoduchý čap

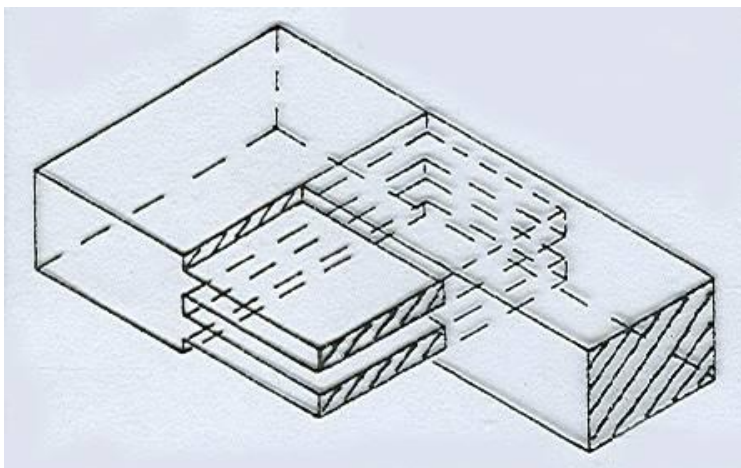

Dvojitý čap – po hrúbke

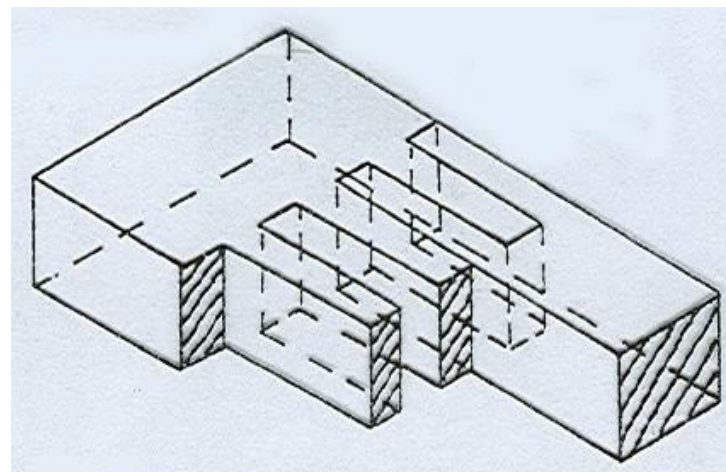

Viacnásobné čapy (rovné ozuby) - po šírke

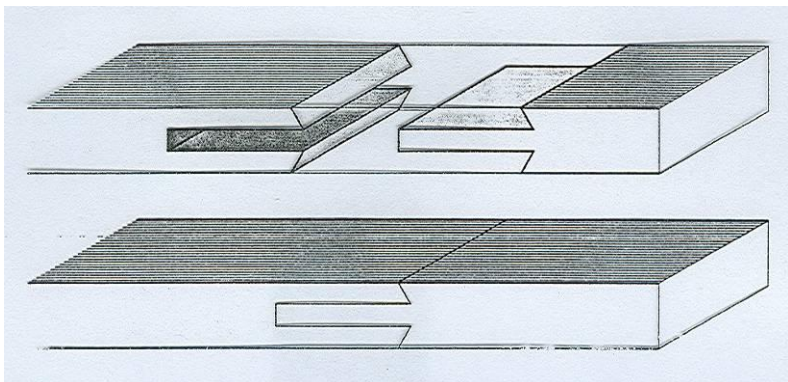

Jednoduchý čap – so skoseným osadením

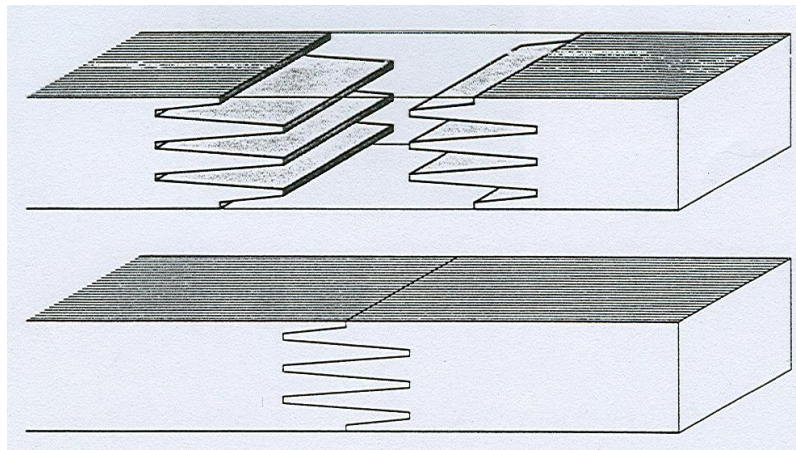

Klinové ozuby, zrezané – po hrúbke

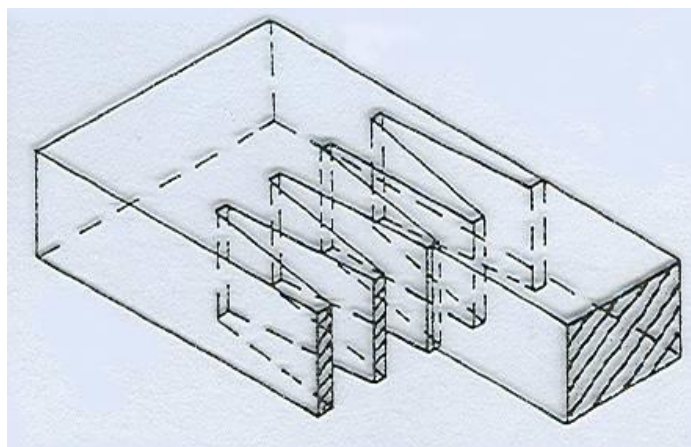

Klinové ozuby, zrezané – po šírke

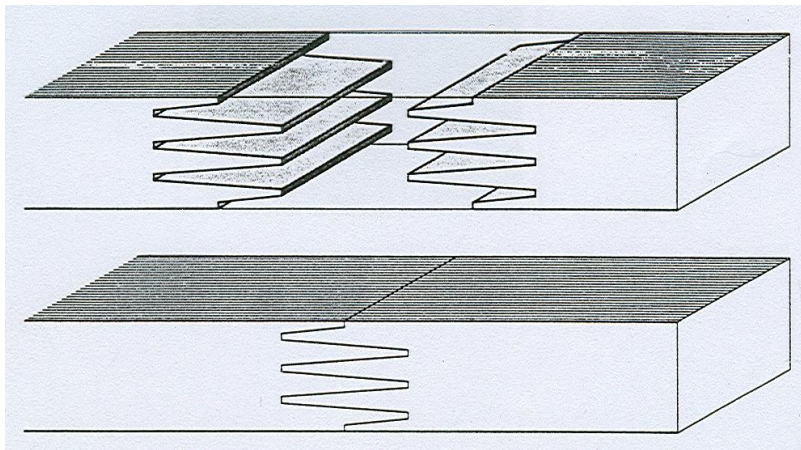

Klinové ozuby, ostré - velké

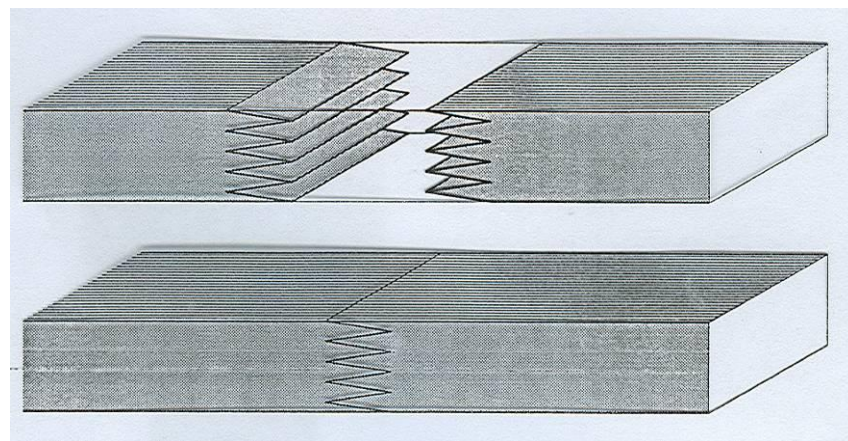

Klinové ozuby, ostré - středné

Účinnosť

- Na tupo – len 25 % účinnosť
- Na zošikmenie
 - 1:10 až 85 % účinnosť
 - 1:15 až 100 % účinnosť
 - nevýhoda – veľký odpad materiálu (až 10 %)
- Na klinové ozuby
 - vysoká účinnosť, 85 – 100 %
 - menší odpad